

This article is intended for those who have never built a duration type indoor plane, are convinced that they can't, but don't realize that, with a little help, they CAN.

Where to start? My preference is the Limited Pennyplane (Most of my friends still call it a Novice Pennyplane, and so do I). get a plan of a successful plane e.g. Banks Pennyplane or copy a model of a club member. If you don't have a building board try a piece of plain ceiling tile. Buy sharp dressmaker pins. You need some good quality cardboard for templates; I bought a sheet of picture matt material from Michaels, a local general handicraft store that also frames pictures. Any light color is O.K.

**The Wing.**

Draw and cut out the wing outline template. It will look something like this:

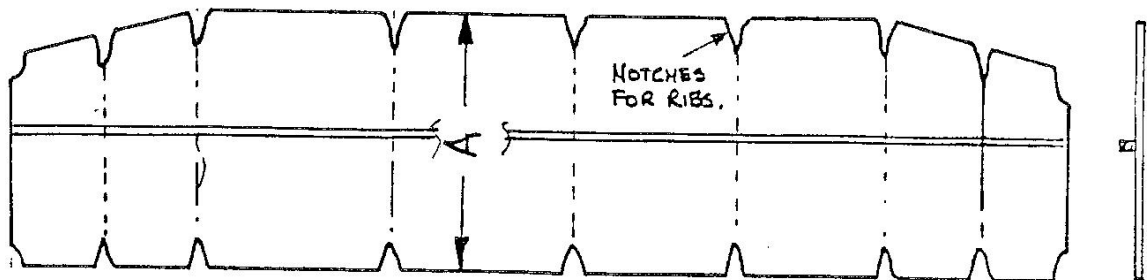

Dimension A is important. The completed wing must not exceed 5.0 inch chord. Lets assume that the L.E. and T.E. are 1/16 sq. (medium). Lightly sanded assume .06 in.

Make Dimension A =  $5.00 - .06 - .06 - .04 = 4.84$  in.

The .04 is insurance against exceeding 5.00 in. finished chord. The spar is to stop the d--- ribs falling over and to stiffen the template.

Draw and cut out the wing rib template. Mine look like this:

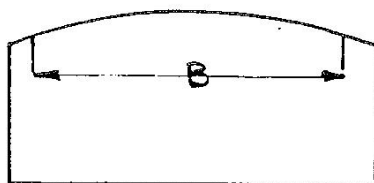

The two marks are the ends of the completed rib. Make dimension B a hair more than dimension A.

Ribs. Get your rib material, probably 1/32 medium light sheet, and cut a piece length B (a hair more than A) off the end of the sheet. Both ends of this cut must be clean cuts. Use the template and a sharp razor blade (not a balsa knife) to slice off ribs that look like this:

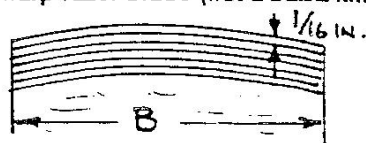

Eye ball the 1/16 in.

Some ribs may be deeper than others. Save these for the dihedral joint and center ribs.

Assembling the wing. Put the usual wax paper etc. on the board and pin the wing template securely down on top of it. Make sure that the board is flat. find some old medium soft 1/8 x 1/16 strip. cut off a zillion little blocks about 3/16 in. long. Use these with pins to fasten the L.E. and T.E. against the template like this;

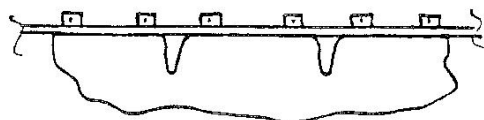

Do NOT push the pins thru the structure OR against one side of it.

Now insert the ribs in place. If you made a pair more than A, they will be a nice snug fit. The dihedral ribs should be canted inwards by about half the dihedral angle. Use Cy glue (not the thin stuff) or acetate glue, put a tiny drop on the end of a tiny screwdriver (or similar 1/32 across) and apply to each rib joint. When dry remove all the pins. When doing this stick a finger on the structure so you don't lift it with the pins. Pry the wing structure off the template with a lot of patience and a few well chosen words! With the wing finally free you will be appalled at its floppiness (technically called low stiffness). Don't worry, compared with an EZB its like iron!!

Weight recording. you should get in the habit of weighing parts as you go along. You can jot them down on the wing template. Do not rush out and buy expensive scales. I made one like that described in Ron Williams excellent book (Alas, not available). It looks like this:

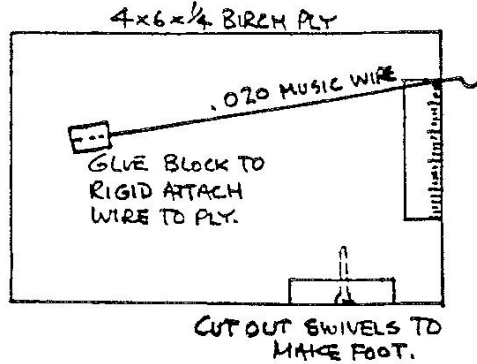

When finished you must calibrate it. A NEW penny weighs very close to 2.50 grams. The old copper ones were 3.1 grams, from which the Pennyplane gets its name. Use a very small piece of thread and sticky tape to hang the new penny on the wire hook. Measure EXACTLY how much the wire deflects at the edge of the wood (C in.). Remove the thread and tape and Hang this on and measure the deflection (D in. not much).

Make a paper scale C - D in. long graduated linearly from 0 to 2.5 and paste it along the ply edge. Tweak the wire if necessary to sit on zero. The use of a linear <sup>SCALE</sup> (equal length divisions) is not quite accurate but will do for now until you can locate some accurate 0.50 gram weights. Beware, some mail order weights are way off. Like I said, weigh the bare wing and later covered. Do this for every part of the plane. For future models this will indicate where you need to reduce weight or add material for more stiffness.

Stabilizer and Fin. The method is similar to the wing construction. Should be a breeze, except that you may be using thinner wood.

NEXT MONTH. of wing stands like this;

Covering with plastic film.

In the meantime make a couple

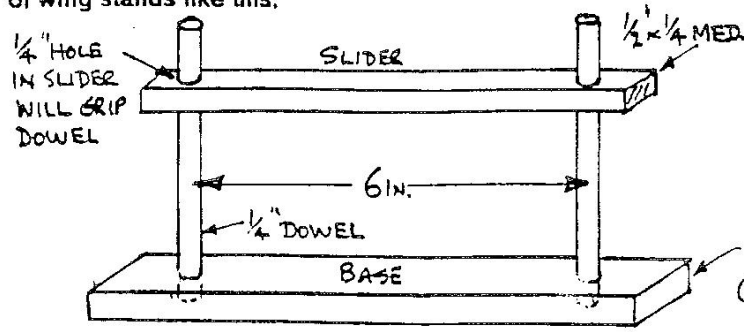

These will be used for setting up wing dihedral, and for on the field repairs after you get clobbered by a HLG, some other clod, or your sleeve catches a wing tip!!!

1" x 1/4" SOFT (TO PUSH PINS THRU)



## COVERING - IT AIN'T EASY (UNTIL YOU'VE DONE A FEW)

**INTRODUCTION.** By now you should have built your Novice (Sorry! 'L i m i t e d') Pennyplane wing and tail feathers. If not, GO to PART 1 and do it! For the good guys, you should cover your indoor duration plane with one of the modern plastic films. These vary from .000060in. down to around .000023in. One supplier quotes .000006in. ( 6 millionth's) which I find hard to believe! Any of these will be OK, but you may find the thicker stuff easier to handle. I buy mine from Wayne Trivin and Dick Obarski. It comes in 15ft. rolls. Expect to waste quite a bit with your first attempts to use it.

Covering with this type of material is totally different from Jap tissue or condenser paper. It has no inherent stiffness and is full of static. If you let go of a piece it will collapse into a heap like Handi-Wrap only worse. From a strength point of view its a bit like cellophane. Once you have something covered, it is surprisingly resistant to puncture, but if you get a tear started then watch out!

Let's cover the Pennyplane wing and tail which you built last month along with the pair of wing supports. The covering sequence will be:

1. The wing and tail must be flat with no dihedral.
2. Construct a film mounting frame.
3. Mount the film on the frame.
4. Place the wing (or tail etc.) on the framed covering.
5. Adjust the frame to roughly match the rib contour.
6. Apply adhesive.
7. Trim the covering thus cutting loose from the frame.
8. Add dihedral and remove the resulting slack.

You may read articles which describe different covering sequences, but start with my way and you will be less likely to get into a mess. But do experiment later. Now for details.

**FILM FRAME.** First construct a lightweight rectangular frame whose inside edge is at least 6.5x20. However you fashion this frame, it must be flat to start with and have stiff spanwise sides. With the film mounted on the frame, you must be able to introduce slack by pulling the sides together. This will let the covering conform to the rib contour. One way to achieve this is to have bendable end pieces made from aluminum wire or possibly strips cut from a soda can. Another rather more complicated method which works great is my way. This uses a screw adjustable gizmo that looks like this:

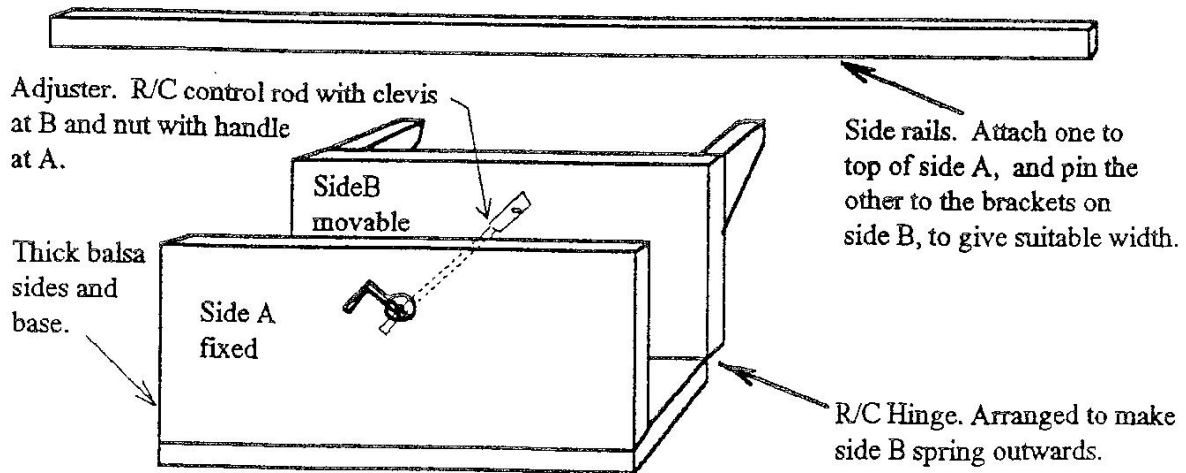

The hinges are essentially flat pieces of nylon. Arrange them to make the moving side to spring outwards. The top rails are hard balsa or spruce etc. The rail on the moving side can be pinned to the side B brackets allow different frame widths for other models. The idea of this contraption is that the film slack can easily be adjusted by turning the handle. It is a bit cumbersome, but it works fine.

**MOUNT THE FILM.** Use a slightly damp cloth to wipe off your work board. When dry, lay the roll of film down at one end and start to unroll it. don't worry if it starts to cling together, but be very careful NOT to start a tear. With a brand new razor blade cut off a piece at least 1in. larger all round than your frame. Go slowly because the razor may snag in the film and tear it. Roll up the remaining film and stow it. Now pick up your cut piece and wad it up (you heard !) real tight. Now spread it out again, as flat as you can, on your board. It will have fine wrinkles and less static. fasten it down to the board with about ten little bits of tape and, if possible, tighten it a little at the same time.

**Prepare Adhesive.** Use any type of contact adhesive, including rubber cement, that can be thinned to a rather watery consistency. I use Elmers SAF-T Contact Cement. This is water soluble. Check building supplies and craft shops. carefully lay the frame, topside down, on the film. Using a small brush apply the thinned adhesive so that it wicks between the frame and the film. Let it dry. Press down on the frame to make sure it adheres to the film. With a razor cut loose the bits of tape and slowly lift the frame and support it right side up.

**COVERING.** Covering is done with all surfaces flat just as they came off the building board. Do NOT sand cute airfoil type tapers into the L.E. or T.E. ; it will not improve the aerodynamics, but it will weaken the members considerably. Lets start with the wing. Lay it upside down on the film. Introduce slack by bending the frame wire ends, or by cranking the handle of my frame. You need just enough slack so that both L.E. and T.E. sit down on the film thus:



**Apply adhesive.** With a tiny brush apply a little thinned adhesive to wick in on the L.E. and T.E. at the dihedral ribs. Let it dry. Go around the entire outline and across the dihedral ribs with adhesive, using as little as possible and let it dry. It may be necessary to push down on the structure to make it stick. Now for the fun part! the film must be trimmed all round the outline to cut it loose from the frame. There are two ways. The first is to use a brand new razor blade from which all traces of stickiness have been removed to minimize the chance of snagging the film. The second is to use a hot wire or cautery having first practiced on a spare area of film, being careful not to pause at any one spot since you may bum the balsa or melt a hole in the covering.

I have used both methods but I prefer the hot one. Which ever you choose you may want to put something under the wing to support it as it drops.

**DIHEDRAL.** Fasten the center wing to the board, on wax paper, with pins angled across the L.E. and T.E. Slice almost thru the L.E. and T.E. at an angle just outboard of the dihedral rib, so that the rib remains attached to the inner wing. Lift the wing tip to crack the spars and prop up on a wing support (you did make the supports I hope!). Pin the base of the support to the board and raise the slider to give the correct dihedral, plus washout if the plan calls for it. Add pins if necessary to hold the dihedral joints together. Repeat for the other tip and check that the span does not exceed 18.00in. Glue the joints with Oya and remove the supports.

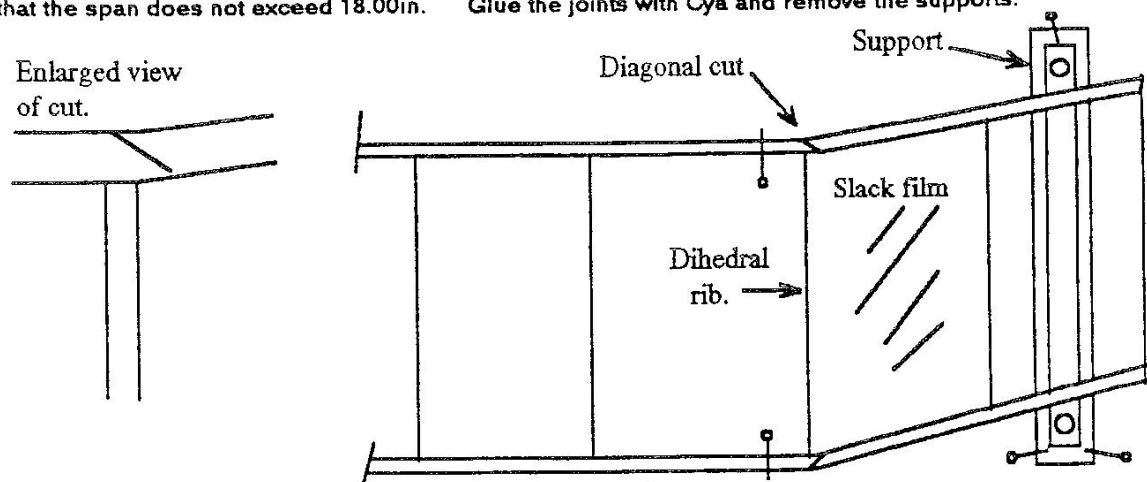

How to get rid of the slack film on the outer wing? Easy. With your fine brush paint a line of thinned glue just outboard ( $1/32$  to  $1/16$  in.) of the dihedral rib. Get a piece of  $1/16$  th. square and slice the end to look like a chisel. Apply it to the bottom surface about mid-chord and slide it inboard to chase the slack to the rib until a downward tuck forms. The glue should hold it here. Repeat all across the rib until all the slack is gone. If it does not hold, wait until the contact glue has got tacky and try again.

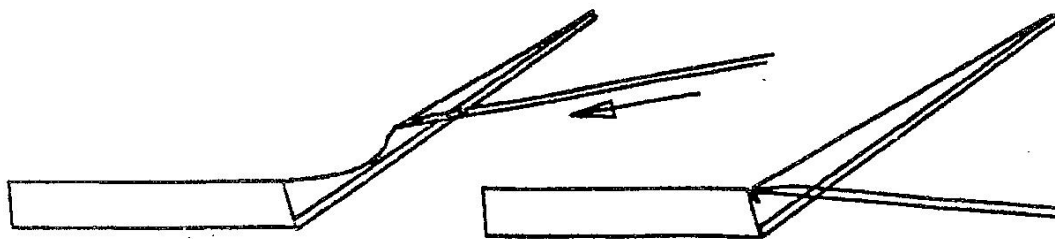

Cover the tail feathers in like fashion.

NEXT MONTH. Prop. motor stick etc., and final assembly. In the meantime make a jig to set up the wing attach tubes to the motor stick like this:

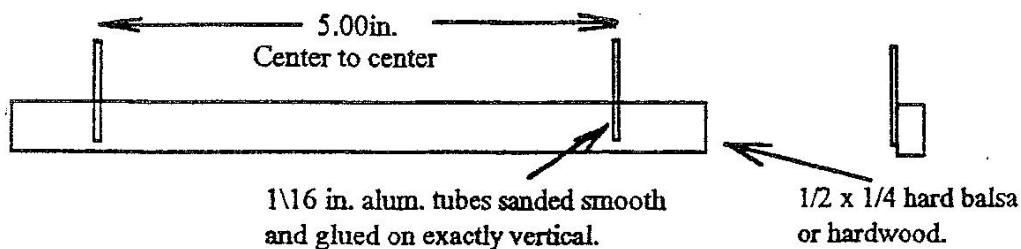

(THEY DO MORE THAN YOU MAY BARGAIN FOR !!)

**INTRODUCTION** If you read Parts 1 & 2 you may by now have ventured into the field of indoor duration. You may also have built and covered the wing and tail feathers of your Limited Pennyplane, together with a jig to position the wing mount tubes on the motor stick. Last month I got carried away and indicated that we would be finished with this article right here. I bit off more than I could chew, so you will have to be satisfied with words of semi-wisdom on the motor stick and tail boom assembly. Why so much space for such mundane items? Read on.

**MOTOR STICK DISCUSSION.** The prime function of the motor stick is to support the wing, tail boom, prop and rubber motor. Unfortunately it does more than that !! Lets consider what it does when you wind up your motor:

1. It Bends. i.e. it arches up in the middle due to the tension between the motor hooks. This induces some negative tail incidence and some downthrust. Both of these are quite small for a fairly robust limited pennyplane.
2. It Twists. For the tail this imparts a left tip down tilt, which tries to make the plane turn right (not desirable). For the wing, it twists the left wing L.E. up and T.E. down (wash in) which assists the normal trim for left turn. It also imparts a small deflection in the yawing direction.
3. Both the above will change as the motor unwinds, especially during the initial burst of power.

For early flying it is easier to trim if the above effects are minimized by keeping the motor stick stiff. bear in mind that a stick of lightweight wood (up to 7 lb./cu.ft.) and generous proportions will be much stiffer than a thinner stick of heavier stock. Enough talk, lets build.

**WING AND TAIL MOUNT TUBES.** These tubes are made by rolling jap tissue around a mandrel and impregnating with cement. Start with the 1/16 in. inside dia. tubes which carry the wing pylon sticks. Cut a strip of jap tissue about 3/4 in. wide and several inches long. Use the shank end of an undamaged 1/16 drill as the mandrel. Rub the shank end on a candle stub and remove any residue with your fingers. Thin some Ambroid (or similar) about 50/50 with acetone. Lay the tissue flat on the work board and proceed as in the diagrams. At (1) paint the mandrel with the cement. (2) roll back to pick up the tissue. (3) roll forward to start the first layer -- use of the brush will help eliminate any slack -- none allowed here. Continue rolling and adding cement for several turns. Cut off the spare tissue and twirl between your fingers to lay the end flat and tighten the coils. (4) Immediately pull the tube off the mandrel with your finger nails and let it drop on the work board. You will ruin a few until you find it is easy. The trick is getting step (3) O.K. Make several spares

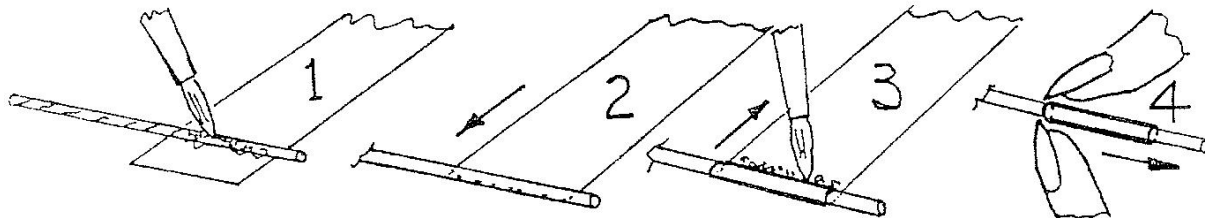

and when dry store them on snug fitting rounded balsa sticks. With an 1/8 drill and tissue about 1 in. wide make the tail mount tube, plus a spare or two.

**MAKE MOTOR STICK AND TAIL BOOM.** Cut the stick and boom per your plan with a bias towards being slightly deeper than shown. When sanding leave the motor stick essentially rectangular cross section. The tail boom can be rounded. Just ahead of the tail position sand the boom to a hair more than 1/8 in. dia. for an inch or so. Later this will be the place for the tail mount tube.

Get the wing mount tubes and slice them to length with a sharp razor while still on the storage sticks. Slide them off the sticks and in to the wing mount jig. Lay this whole thing in the correct position on the motor stick

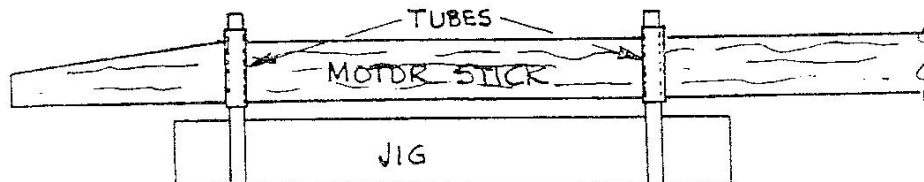

side. Shim under the stick or jig so that the tubes sit nice and flat on the side (usually left) of the stick. Glue in place with Cyano. Remove the jig

Now for the prop shaft and rear motor hooks, together with the shaft dual bearing. Every one has their fav. hook shape and rubber sleeves, O-rings, etc. My hooks look like a Z shape when viewed from the rubber bar side. When wound, the motor tends to center itself on this type hook. The shaft bearing has to do two things. First, it must hold the thrust line you want and second, it must let you remove the prop complete with shaft for storage. Ray Harlan does a good bearing, but I make my own from music wire. The general principle of all dual bearings is similar. The front bearing is a plain hole thru which you thread the prop shaft hook. The rear bearing is a devious shape, which allows the hook to be 'screwed' thru or snapped in place and then grips the shaft when in the running position. Here are some sketches (enlarged) of my hooks and bearings.

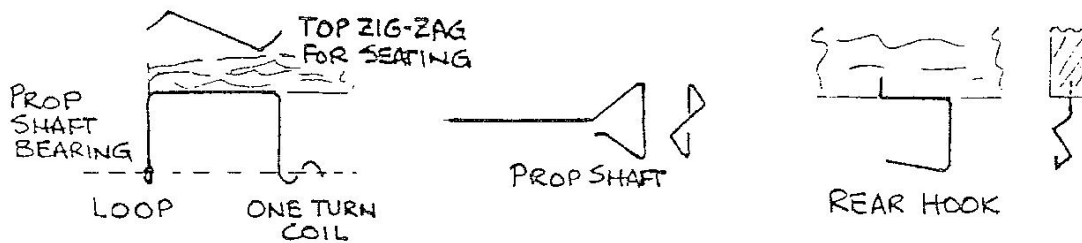

I make my bearing loop and spiral by clamping two pieces of wire in a vice and then winding one around the other. Takes a lot of practice to get it just right. The front face is then stoned to remove any sharp projections.

The front bearing and rear hook are both attached by binding a few turns of a strip of jap tissue and thinned Ambroid. A short piece of wire the same dia. as the prop shaft will help you align the bearing. You will need about 2 degrees of left sidethrust. Remember to allow for any slop which will straighten out with a wound motor.

Now for the tail boom. Fasten it down on the building board with pins and blocks. Set the horizontal stabilizer

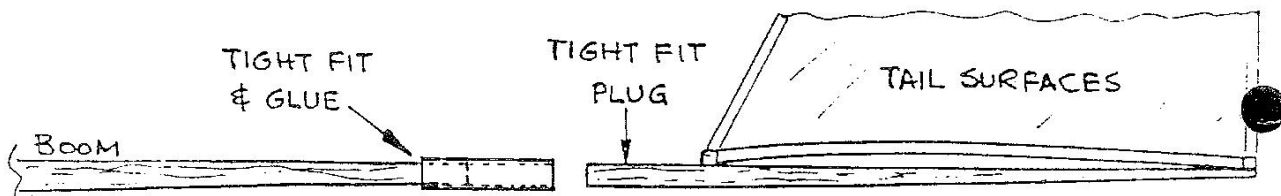

in place and cement it. Likewise for the Vertical. If you have a droop down tail, block it up to clear. Remember the approx. 1/8 in. dia. bit sanded ahead of the tail? Cut thru it about one third back from its front end. Get the paper tail tube and cut it to length (approx 3/4 in.). Sand the front part of the cut to make it a tight fit on the tube. Insert about 1/4 in. and glue it. Sand the tail half of the cut to be a tight but removable fit. This will tend to loosen in time but a thin coat of Cya will take care of it. If you fly in a site where the plane can hit obstacles (and Who doesn't?), put a small smear of Ambroid to secure the plug in part. Have a small bottle of acetone with you to loosen it later. If the boom is separate from the motor stick, they can now be joined.

**WING MOUNT ASSEMBLY.** Sand the lower 1/2 in. or so of the wing pylon sticks for a stiff fit in the motor stick tubes. Insert them in the tubes flush with the bottom. Pin the motor stick to the work board with the pylon sticks vertical. Support the wing using the props you used earlier so that the wing sits at the correct height between the pylon sticks. If all is well, the sticks should rest lightly against the L.E. and T.E. At this time you should include anywing twist called for, usually some left wing wash in (T.E. down). I use less than 1/8 in.

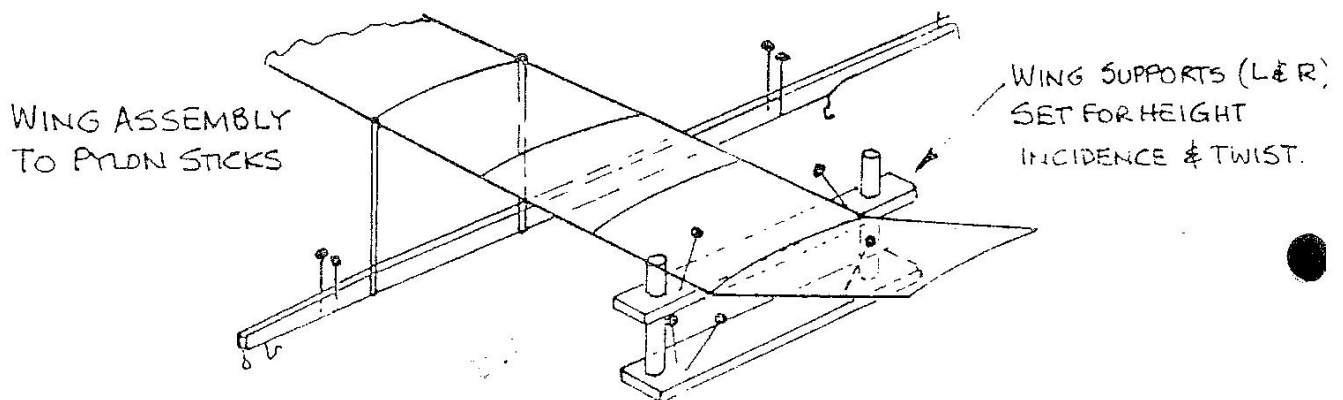

When everything is in the correct position, glue the pylon/wing joints with Cyanoacrylate. I stopped using Ambroid for these joints after a small amount of creep occurred in storage which ruined the trim. If the plan calls for air diagonal braces, these can be added now. Remove the wing assembly and weigh it. Likewise the motor stick + boom and tail assemblies.

**NEXT MONTH** We will make the prop and give brief flying hints. However let's conclude with some fun. add some ballast to the nose to make the model balance at about 65% of the wing chord. Set the wing at a slight positive incidence relative to the tail. Set the right tail tip about 1/4 to 1/2 in. down. Test glide in your best clear space indoor (Air OFF). Adjust wing setting until almost stalling. It should turn slowly left and amaze your friends by its lack of speed !! Maybe not. It reminds me of a morning when I was giving an indoor flying demo to a bunch of about 80 sixth graders. My Pennyplane was steadily climbing to the gymnasium roof accompanied by ooo's and ahhh's from all except one boy who asked "Sir, can you make it fly any faster?"

---



### INTRODUCTION

If you read Parts 1 thru 3, you may already have built and covered the airframe and perhaps had some fun with test glides of a Limited (Novice) Pennyplane. However to get that model to the roof of the local school gym, or tangle with the roof at E.T.S.U. in Johnson City, you need a propeller and rubber band motor. For the novice to indoor free flight these easily can be the most neglected items. Volumes could be written about them, but we only have enough space to touch on some of the basic principals to get started. If you get hooked on indoor duration flying, the rubber motor can get quite expensive because you will need a rubber stripper, a winder with counter, and one or two torquemeters. However lets start with the propeller.

### PROPELLER BASICS

Your plan will give you a good idea of the propeller construction. It will have thin molded light sheet blades attached to a single stiff spar.

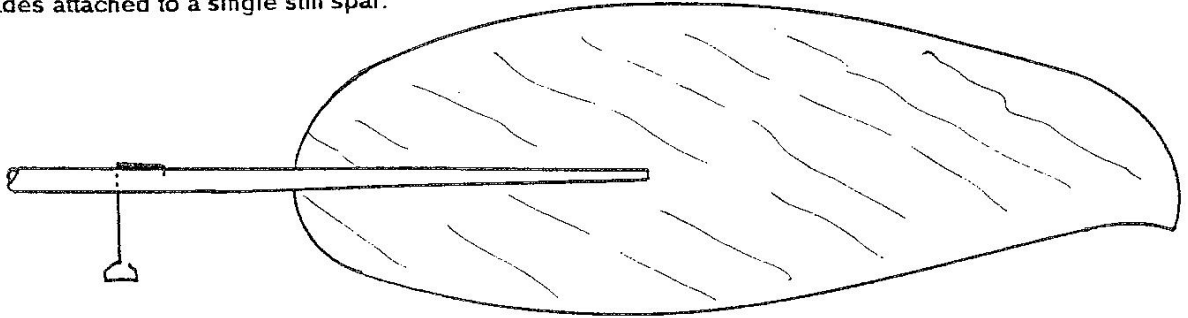

**The Bare Blade.** This will usually be made from 5 to 6 lb. C grain balsa. The grain may be shown straight or on the diagonal. The blades must be cut from the sheet so as to give a good stiffness match. Blades are usually sanded to taper in thickness, typically from about 1/32in. at the root to perhaps half that at the tip. For sanding this thin, you must set the blade on a very flat surface (I use a 12in. square tile) and the sandpaper must be glued to a very flat block such as a piece of 1/2in. sheet balsa. It is important to match the blades for thickness and weight. The spring scale and a micrometer will help.

**Molding The Blade Twist.** Theoretically the optimum blade twist is for helical pitch which requires a carved

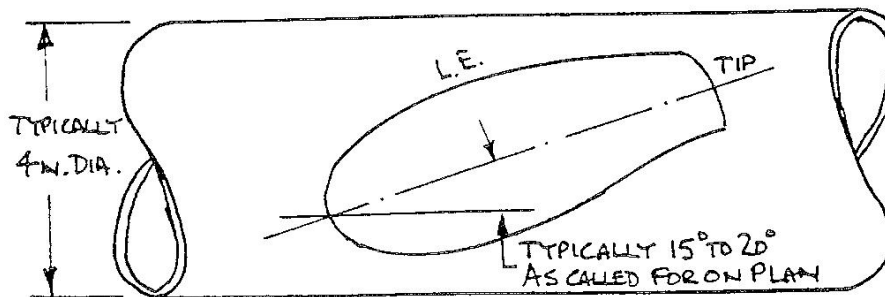

block former, but we will use a simpler and quite good method which involves setting the blade at an angle on a cylindrical surface. This method also induces an airfoil section to the blade. You need a smooth can, bottle or pipe of 4 in. dia. or as indicated on your plan. If the item you find is not quite the right diameter then the angle must be changed. The bigger the diameter the steeper the angle. Mark this angle on the former, twice, 180 deg. apart, together with blade outlines. Mark the spar lines on the blades, tip to tip. Prepare about 12 strips to hold the blades on the former, like this:

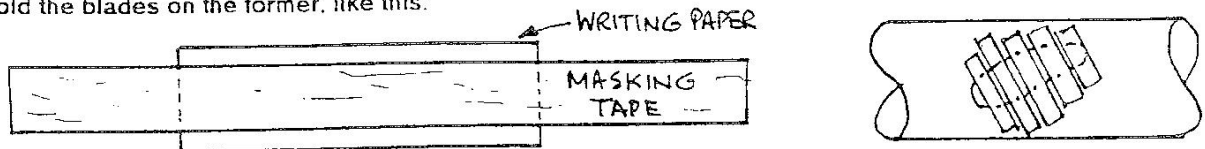

Get an Ace bandage [no, don't steal it from the first aid kit!]. Set the oven to heat to about 200 to 230 deg. Boil water, pour into a pan and add about two table spoons of household ammonia for each cup of water. Throw in the blades. Cover, or otherwise keep hot for ten minutes. The heat plus ammonia softens nature's glues in

The E  
There  
CO<sub>2</sub> car  
have to  
ive. It  
chit

the wood and will clear your sinuses. Fasten the blades on the former using the prepared strips. whole thing with the bandage and bake for an hour. Remove from the oven and let it cool. I usually overnight. Uncover and carefully ease the blades off the former. Cut a slot for the spar if the plan calls fo,

**Propeller Assembly.** For the spar cut and sand a piece of medium hard 3/32in. or 1/8in. to the shape shown on the plan. Make a tiny hole in the center and insert the prop shaft. Bend and cement like this:

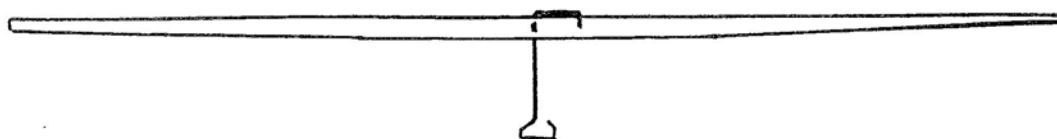

Make a prop assembly jig as shown below:

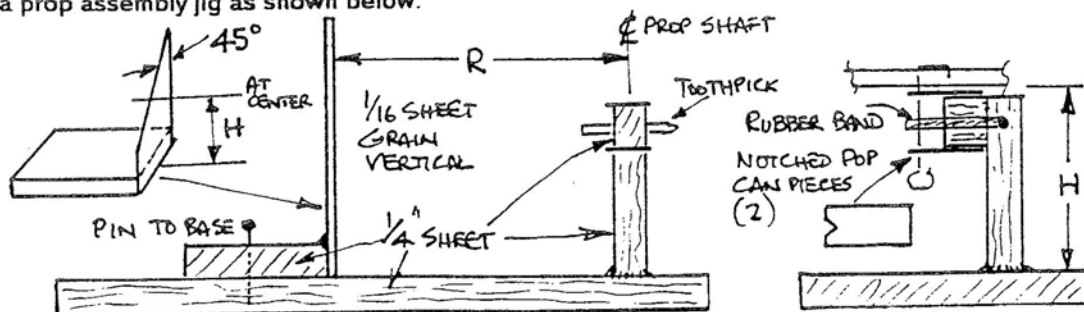

It is important that the notches for the shaft are aligned exactly vertical and that the center of the 45 deg. support is close to the height 'H'.

Fasten the shaft/spar item in the notched part using a small band hooked on to the toothpick. Rest one blade on to the spar and the 45 deg. piece. the blade will want to slide off the support. Use a pin to provide a stop. You may need to reposition the 45 deg. piece laterally to get the right height. The spanwise position 'R' sets the pitch.  $R = 0.159 \times \text{Pitch}$  (For 20in. pitch  $R = 3.2\text{in.}$ ) When it all looks good, apply Cya at the ends and a several points along the spar. Repeat for the other blade. Remove and admire your superb handiwork. Add a small nylon washer and weigh it.

**Balancing.** Clean off any ballast from the front of your motor stick and insert the propeller. Make certain it revolves freely. If one blade appears much heavier than the other, do some careful sanding. Don't worry too much about static balance. Go fly it. If it wobbles, it means that the blades are set at, or are flaring to, unequal angles. Check and tweak as necessary. Suffice to say that usually the wobble is affected more by unequal blade angles than by static balance.

### RUBBER BAND AND FLYING

Weigh the complete model without rubber. It must be at least 3.1 grams. For power, TAN 2 is the best. However it only comes in widths suitable for outdoor flying, 1/4in. etc. If your model is close to the nominal 3.1 grams, you will need some cut to .075, .080, and .085in. for starters. If your model is heavier, the sizes will have to be bigger. The way to get rubber of various odd sizes is to call Indoor Model Supply, or get someone who has a stripper to cut it from your 1/4in. strip. Please DO NOT ask a friend to do this on a contest day. Whatever you choose, make a small loop, say 4in., lube it (I use STP Son of a Gun protectant), break it in, then stretch wind it until it breaks. Calculate the breaking turns/inch. Make an 18in. loop of .080 and wind it to about 70% of breaking and then back down to 50%. With these turns trim the model close to the stall with wing post settings and the desired left turn with stabilizer tilt, right side down. If it climbs at this 50% [backed off] turns, the motor is probably too thick or too short. Similarly if it sinks, the motor is too thin or long. Either way, just wind up some more until you get a decent flight. MAKE NOTES for each flight; trim settings, motor size & weight, and flight time. Count the number of turns left at the end of each flight and calculate prop revs:

$$(\text{Turns wound} - \text{turns left}) \times 60 / \text{flight time secs.} = \text{R.P.M.}$$

Set a target flight duration for your site (be realistic !!). Calculate a motor length assuming you use 90% of breaking turns :

$$\text{Length (inches)} = \text{R.P.M.} \times \text{Duration Minutes} / [0.9 \times \text{break turns per inch}]$$

Bear in mind that a short motor will not run long enough, but an extra long one will be too heavy. You need to do a lot of flying to get the motor just right for one flying site. So get started and have fun. Nice talking to you.

John

# NOVICE PENNYPLANE

## WING:

LE 1/16 sq-round nose  
 TE 1/16 sq  
 TIPS 1/16 sq to .04  
 RIBS 1/32 x 1/16  
 with 12" arc  
 POSTS 1/16 Round

## STAB:

LE .05 x .04 -round nose  
 TE .05 x .04  
 TIPS .05 x .04 taper to .03  
 RIBS 1/32 x .05, 18" arc

## STICK:

3/16 x 1/4; taper both  
 ends to 1/8 x 3/16

## BOOM:

3/16 x 1/8 taper to 1/16 sq

## PROP:

12" Dia, 22" Pitch,  
 HUB: 4", 1/8 round, taper  
 to 1/16

BLADES: 1/32 sheet, thinned  
 out at tips

WIRE .020" or .025"

## COVER:

Microlite or any thin plastic  
 film - thinned rubber cement

## WEIGHTS:

Wing .031  
 Prop .023  
 Rest .058  
 Total .112 oz

RIBS & PROP BLADES ARE  
 SOFT BALSA; ALL ELSE IS  
 MEDIUM.

Drawn by Keith Varnau

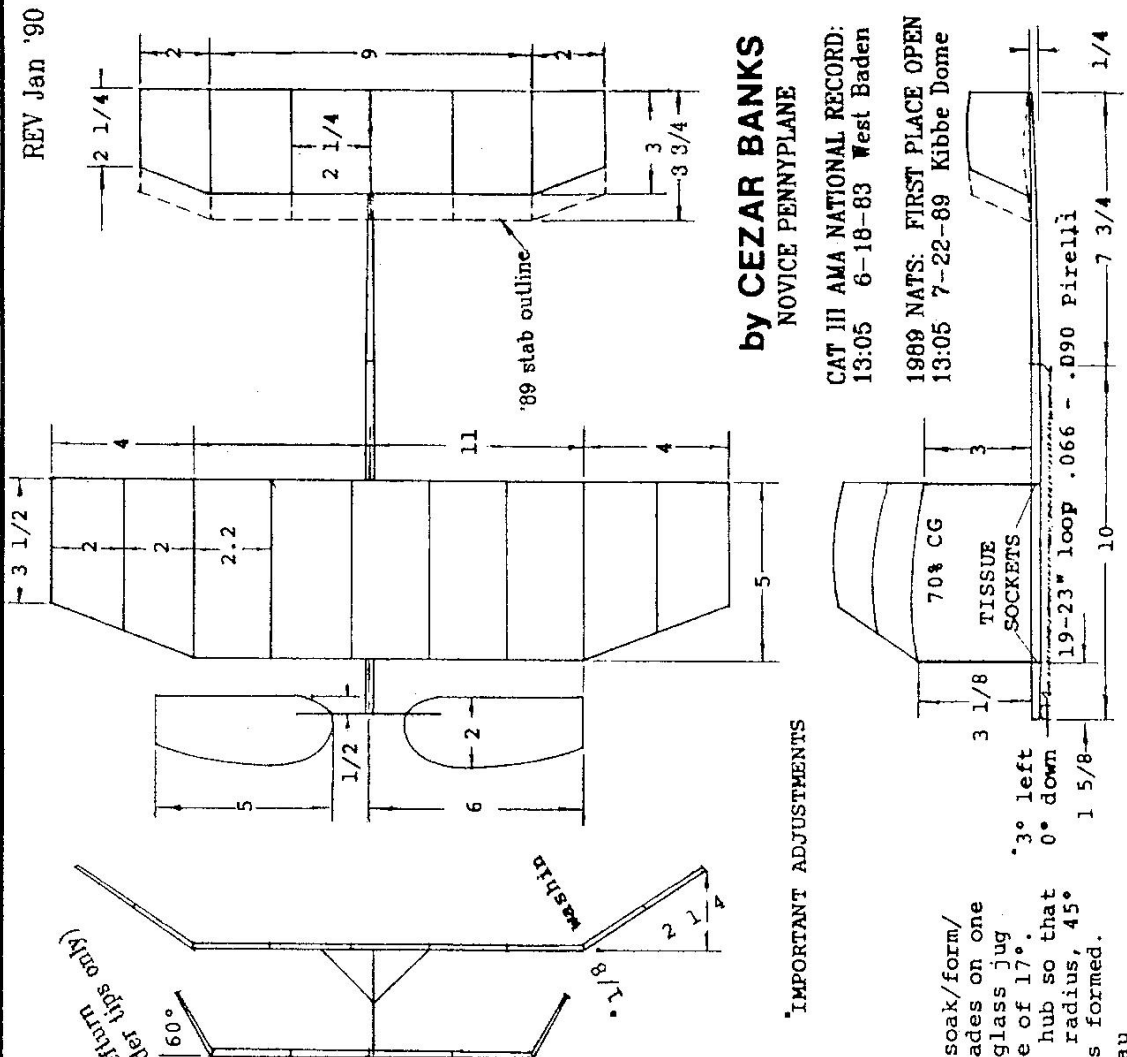

REV Jan '90

by **CEZAR BANKS**  
 NOVICE PENNYPLANE

CAT III AMA NATIONAL RECORD:  
 13:05 6-18-83 West Baden

1989 NATS: FIRST PLACE OPEN  
 13:05 7-22-89 Kibbe Dome

1/4